

13A, 700V SUPER JUNCTION MOS POWER TRANSISTOR

DESCRIPTION

SVS70R360S(F)(FJD)(D)E3 is an N-channel enhancement mode high voltage power MOSFETs produced using Silan's super junction MOS technology. It achieves low conduction loss and switching losses. It leads the design engineers to their power converters with high efficiency, high power density, and superior thermal behavior. Furthermore, it's universal applicable, i.e., suitable for hard and soft switching topologies.

FEATURES

- ◆ 13A,700V, $R_{DS(on)(typ.)}=0.31\Omega@V_{GS}=10V$
- ◆ New revolutionary high voltage technology
- ◆ Ultra low gate charge
- ◆ Periodic avalanche rated
- ◆ Extreme dv/dt rated
- ◆ High peak current capability
- ◆ 100% avalanche tested
- ◆ Pb-free lead plating
- ◆ RoHS compliant

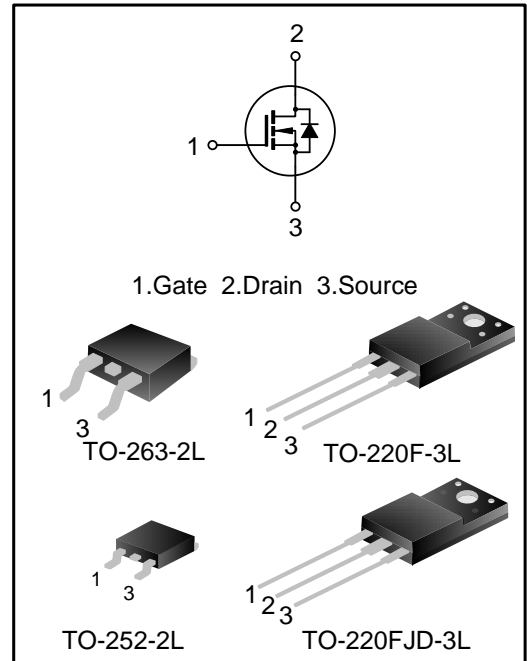

KEY PERFORMANCE PARAMETERS

Characteristics	Ratings	Unit
V_{DS}	700	V
$V_{GS(th)}$	2.5~4.5	V
$R_{DS(on),max.}$	0.36	Ω
$I_{D,pulse}$	52	A
$Q_g,typ.$	27	nC

ORDERING INFORMATION

Part No.	Package	Marking	Hazardous Substance Control	Packing Type
SVS70R360SE3	TO-263-2L	70R360SE3	Halogen free	Tube
SVS70R360SE3TR	TO-263-2L	70R360SE3	Halogen free	Tape&Reel
SVS70R360FE3	TO-220F-3L	70R360FE3	Halogen free	Tube
SVS70R360FJDE3	TO-220FJD-3L	70R360FDE3	Halogen free	Tube
SVS70R360DE3TR	TO-252-2L	70R36DE3	Halogen free	Tape&Reel

ABSOLUTE MAXIMUM RATINGS (UNLESS OTHERWISE NOTED, $T_A=25^{\circ}\text{C}$)

Characteristics	Symbol	Test conditions	Ratings			Unit
			Min.	Typ.	Max.	
Drain-source Voltage	V_{DS}	--	700	--	--	V
Gate-source Voltage (Static)	V_{GS}	--	-20	--	20	V
Gate-source Voltage (Dynamic)	V_{GS}	AC($f>1\text{Hz}$)	-30	--	30	V
Drain Current	I_D	$T_C=25^{\circ}\text{C}$	--	--	13	A
		$T_C=100^{\circ}\text{C}$	--	--	8	A
Drain Current Pulsed (Note 1)	I_{DM}	$T_C=25^{\circ}\text{C}$	--	--	52	A
Power Dissipation(TO-263-2L) (Note 2)	P_D	$T_C=25^{\circ}\text{C}$	--	--	147	W
Power Dissipation(TO-220F-3L) (TO-220FJD-3L) (Note 2)	P_D	$T_C=25^{\circ}\text{C}$	--	--	36	W
Power Dissipation(TO-252-2L) (Note 2)	P_D	$T_C=25^{\circ}\text{C}$	--	--	114	W
Single Pulsed Avalanche Energy	E_{AS}	$L=79\text{mH}$, $V_{DD}=100\text{V}$, $R_G=25\Omega$, starting temperature $T_J=25^{\circ}\text{C}$	--	--	405	mJ
Single Pulsed Avalanche Current	I_{AS}	--	--	--	3.0	A
Reverse Diode dv/dt	dv/dt	$V_{DS}=0\sim 400\text{V}$, $I_{SD}\leq I_S$, $T_J=25^{\circ}\text{C}$	--	--	50	V/ns
MOSFET dv/dt Ruggedness	dv/dt	$V_{DS}=0\sim 480\text{V}$	--	--	100	V/ns
Operation Junction Temperature Range	T_J	--	-55	--	150	$^{\circ}\text{C}$
Storage Temperature Range	T_{stg}	--	-55	--	150	$^{\circ}\text{C}$
Continuous Diode Forward Current	I_S	$T_C=25^{\circ}\text{C}$, integral reverse P-N junction diode in the MOSFET	--	--	13	A
Diode Pulse Current	$I_{S,pulse}$		--	--	52	A
Maximum Diode Commutation Speed	di/dt	$V_{DS}=0\sim 400\text{V}$, $I_{SD}\leq I_S$, $T_J=25^{\circ}\text{C}$	--	--	250	A/ μs

THERMAL CHARACTERISTICS

Table1. Thermal characteristics of TO-263-2L(SVS70R360SE3)

Characteristics	Symbol	Test conditions	Ratings			Unit
			Min.	Typ.	Max.	
Thermal Resistance, Junction-case, Bottom	$R_{\theta JC}$	--	--	--	0.85	°C/W
Thermal Resistance, Junction-ambient	$R_{\theta JA}$	--	--	--	62.5	°C/W
Soldering Temperature (SMD)	T_{sold}	Reflow soldering: 10 ± 1 sec, 3times Wave soldering: 10_{-0}^{+2} sec, 1time	--	--	260	°C

Table2. Thermal characteristics of TO-220F-3L/TO-220FJD-3L(SVS70R360F/FJDE3)

Characteristics	Symbol	Test conditions	Ratings			Unit
			Min.	Typ.	Max.	
Thermal Resistance, Junction-case, Bottom	$R_{\theta JC}$	--	--	--	3.5	°C/W
Thermal Resistance, Junction-ambient	$R_{\theta JA}$	--	--	--	62.5	°C/W
Soldering Temperature (in line)	T_{sold}	15_{-0}^{+2} sec, 1time	--	--	260	°C

Table3. Thermal characteristics of TO-252-2L(SVS70R360DE3)

Characteristics	Symbol	Test conditions	Ratings			Unit
			Min.	Typ.	Max.	
Thermal Resistance, Junction-case, Bottom	$R_{\theta JC}$	--	--	--	1.1	°C/W
Thermal Resistance, Junction-ambient	$R_{\theta JA}$	--	--	--	62.0	°C/W
Soldering Temperature (SMD)	T_{sold}	Reflow soldering: 10 ± 1 sec, 3times Wave soldering: 10_{-0}^{+2} sec, 1time	--	--	260	°C

ELECTRICAL CHARACTERISTICS (UNLESS OTHERWISE NOTED, $T_J=25^{\circ}\text{C}$)

Static characteristics

Characteristics	Symbol	Test conditions	Ratings			Unit
			Min.	Typ.	Max.	
Drain-source Breakdown Voltage	BV_{DSS}	$V_{GS}=0V, I_D=250\mu A$	700	--	--	V
Drain-source Leakage Current	I_{DSS}	$V_{DS}=700V, V_{GS}=0V, T_J=25^{\circ}\text{C}$	--	--	1.0	μA
		$V_{DS}=700V, V_{GS}=0V, T_J=125^{\circ}\text{C}$	--	3.0	--	
Gate-source Leakage Current	I_{GSS}	$V_{GS}=\pm 30V, V_{DS}=0V$	--	--	± 100	nA
Gate Threshold Voltage	$V_{GS(th)}$	$V_{GS}=V_{DS}, I_D=250\mu A$	2.5	--	4.5	V
Static Drain-source On State Resistance	$R_{DS(on)}$	$V_{GS}=10V, I_D=6.5A$	--	0.31	0.36	Ω
Gate Resistance	R_G	$f=1\text{MHz}$	--	6.0	--	Ω

Dynamic characteristics

Characteristics	Symbol	Test conditions	Ratings			Unit
			Min.	Typ.	Max.	
Input Capacitance	C_{iss}	$f=1\text{MHz}, V_{GS}=0V, V_{DS}=100V$	--	1056	--	pF
Output Capacitance	C_{oss}		--	45	--	
Reverse Transfer Capacitance	C_{rss}		--	1.0	--	
Turn-on Delay Time	$t_{d(on)}$	$V_{DD}=350V, V_{GS}=10V, R_G=24\Omega, I_D=13A$ (Notes 3, 4)	--	23	--	ns
Turn-on Rise Time	t_r		--	48	--	
Turn-off Delay Time	$t_{d(off)}$		--	64	--	
Turn-off Fall Time	t_f		--	36	--	
Total Gate Charge	Q_g	$V_{DD}=560V, V_{GS}=10V, I_D=13A$ (Notes 3, 4)	--	27	--	nC
Gate-source Charge	Q_{gs}		--	9.0	--	
Gate-drain Charge	Q_{gd}		--	12	--	
Gate-plateau Voltage	$V_{plateau}$		--	7.2	--	V

Reverse diode characteristics

Characteristics	Symbol	Test conditions	Ratings			Unit
			Min.	Typ.	Max.	
Diode Forward Voltage	V_{SD}	$I_S=13A, V_{GS}=0V$	--	--	1.4	V
Reverse Recovery Time	T_{rr}	$I_S=13A, V_{GS}=0V, di_F/dt=100A/\mu s$ (Note 3)	--	348	--	ns
Reverse Recovery Charge	Q_{rr}		--	4.7	--	μC
Reverse Recovery Peak Current	I_{rrm}		--	26	--	A

Notes:

- Pulse time $5\mu s$;
- The dissipation power will change with temperature, derating above 25°C :
 $1.18W/^{\circ}\text{C}(\text{TO-263-2L}) / 0.29W/^{\circ}\text{C}(\text{TO-220F-3L})(\text{TO-220FJD-3L}) / 0.91W/^{\circ}\text{C}(\text{TO-252-2L})$;
- Pulse Test: Pulse width $\leq 300\mu s$, Duty cycle $\leq 2\%$;
- Essentially independent of operating temperature.



TYPICAL CHARACTERISTICS

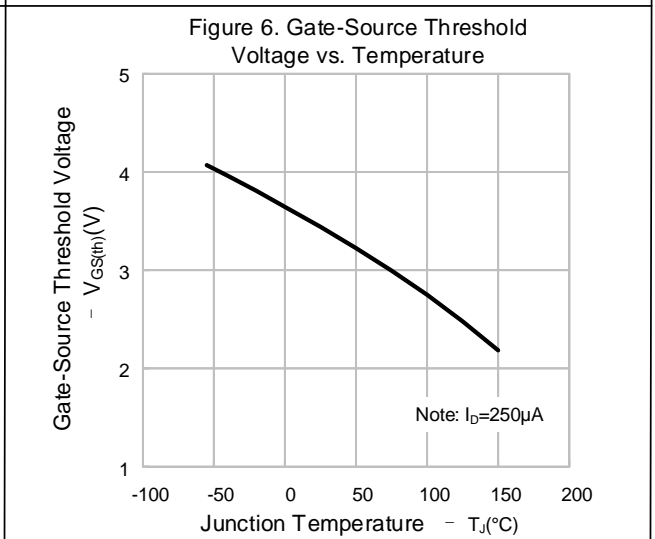
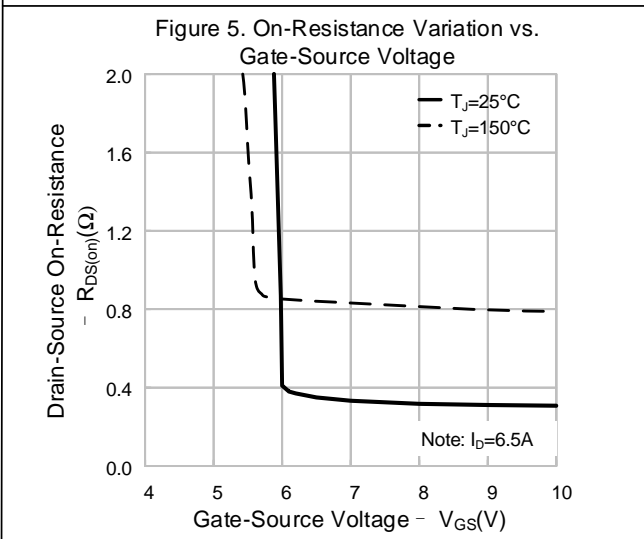
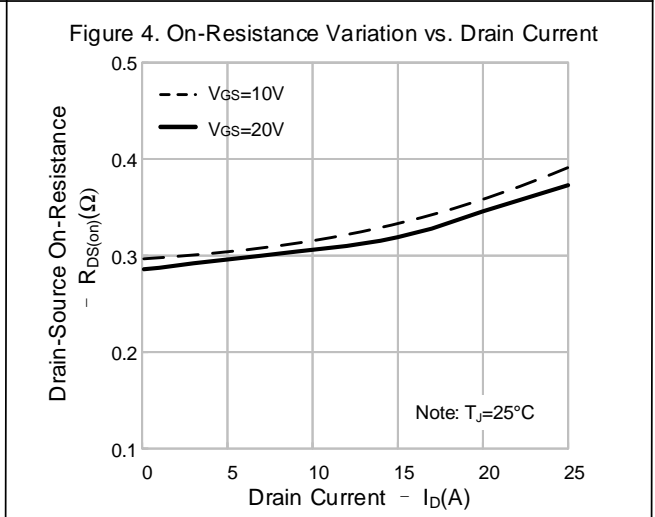
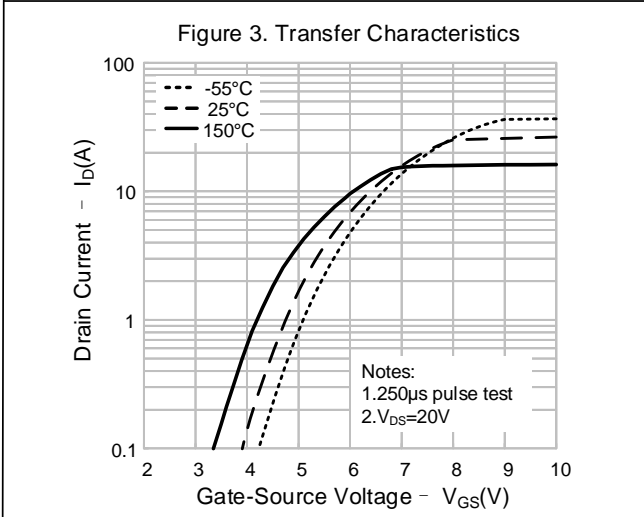
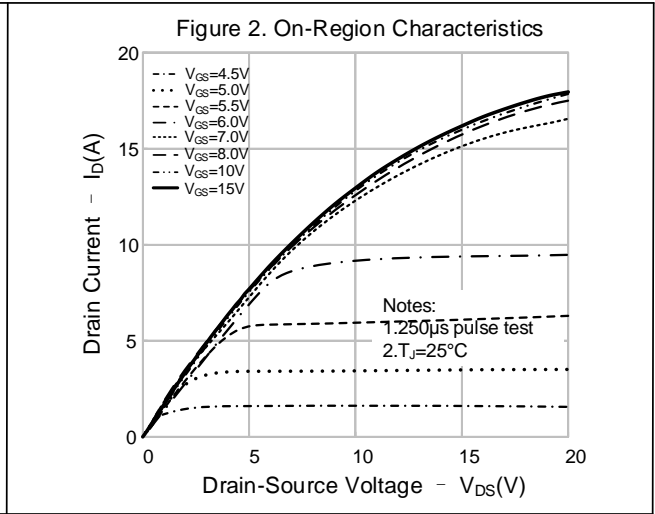
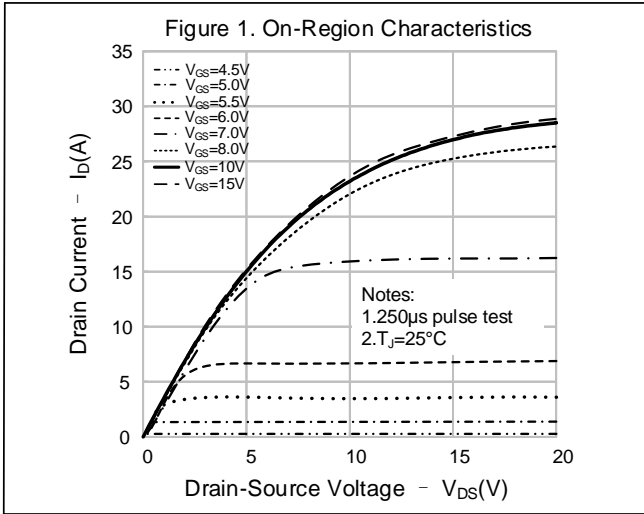



TYPICAL CHARACTERISTICS (CONTINUED)

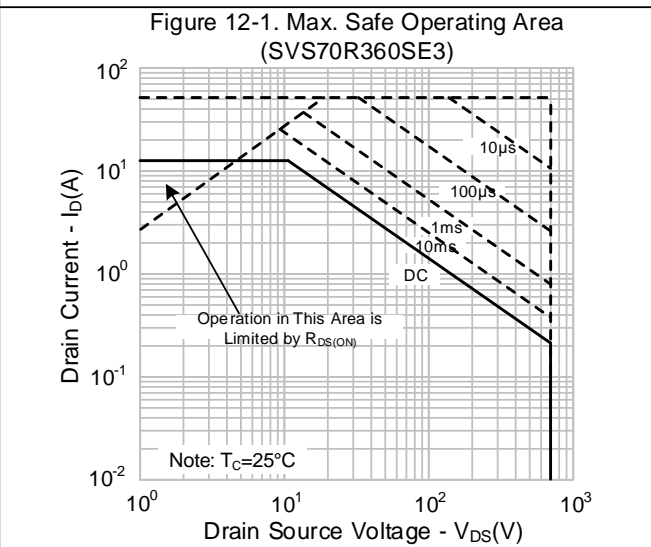
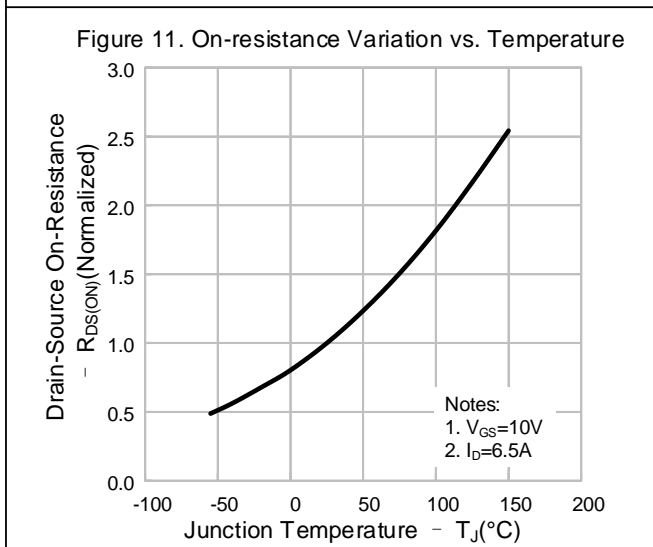
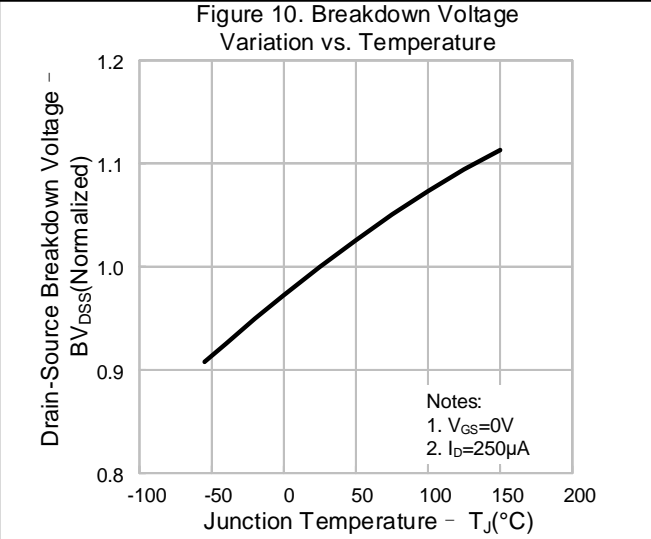
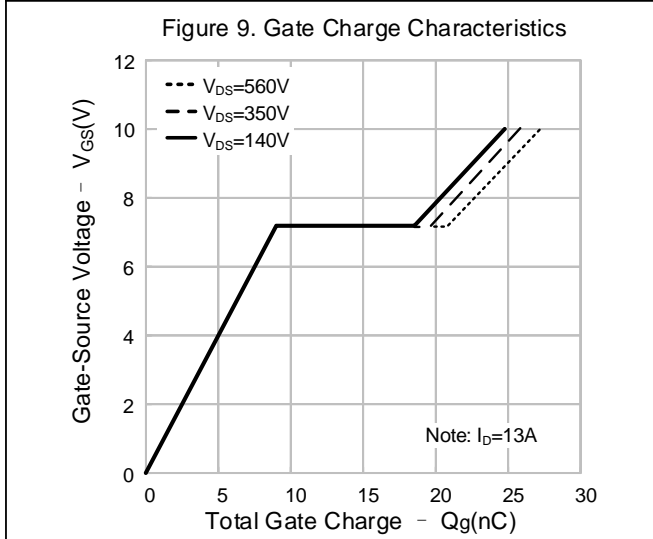
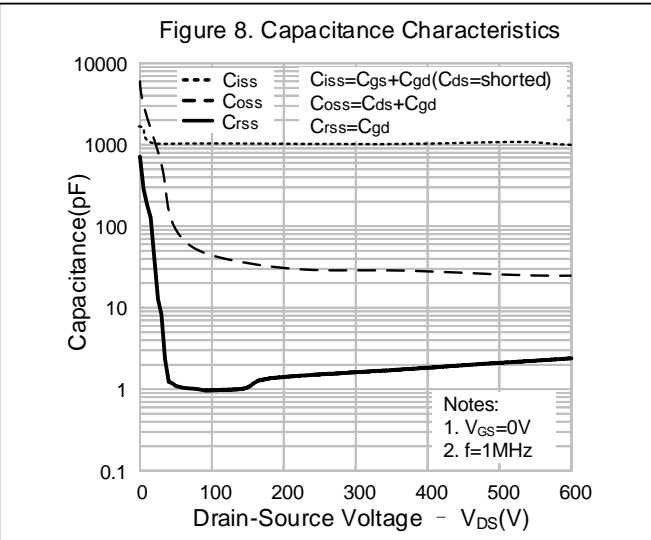
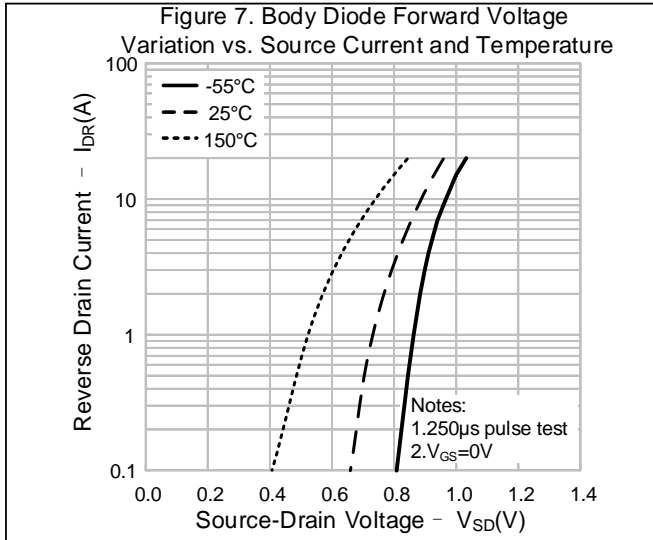



TYPICAL CHARACTERISTICS (CONTINUED)

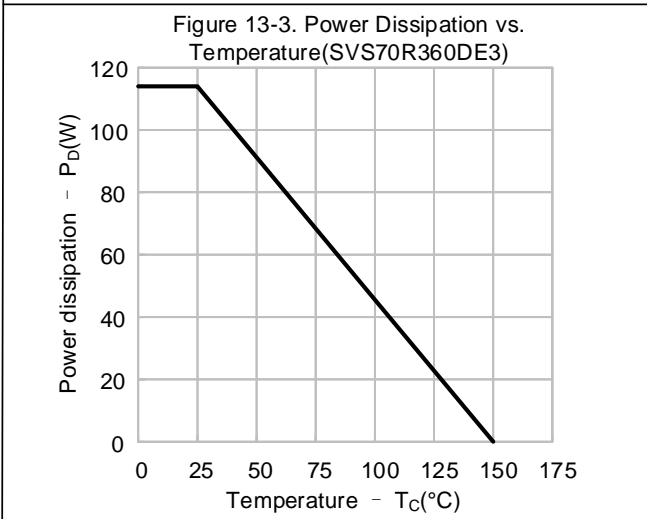
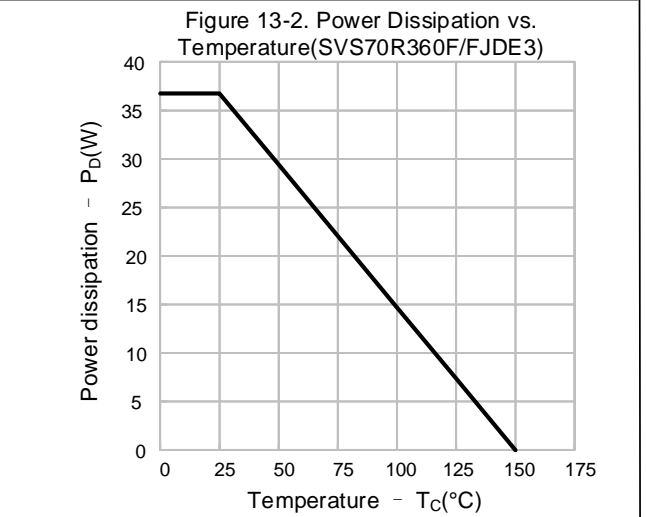
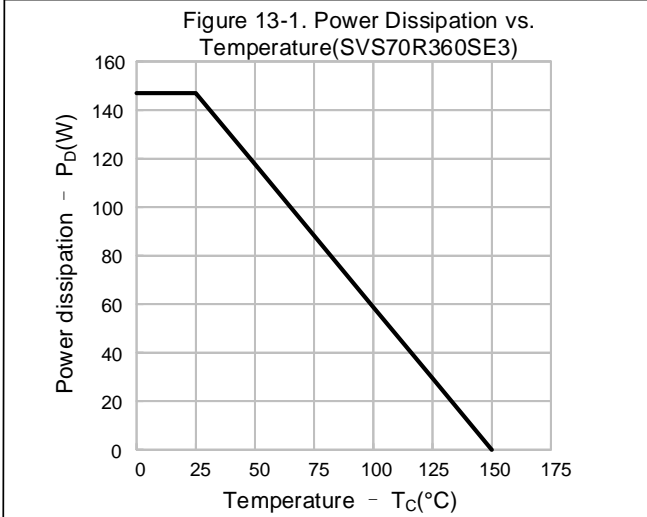
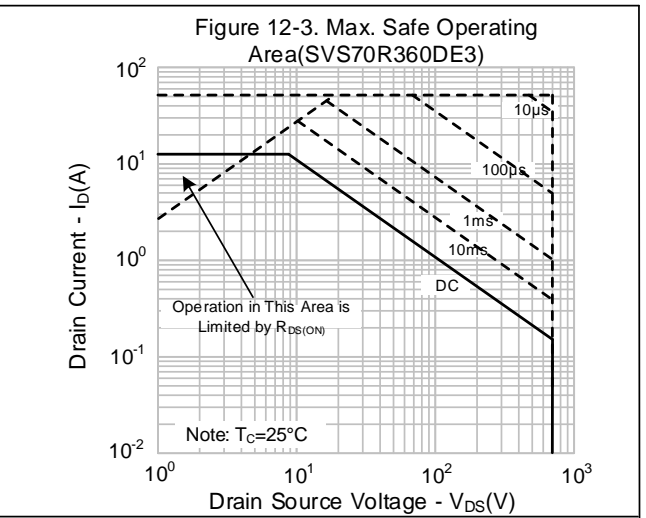
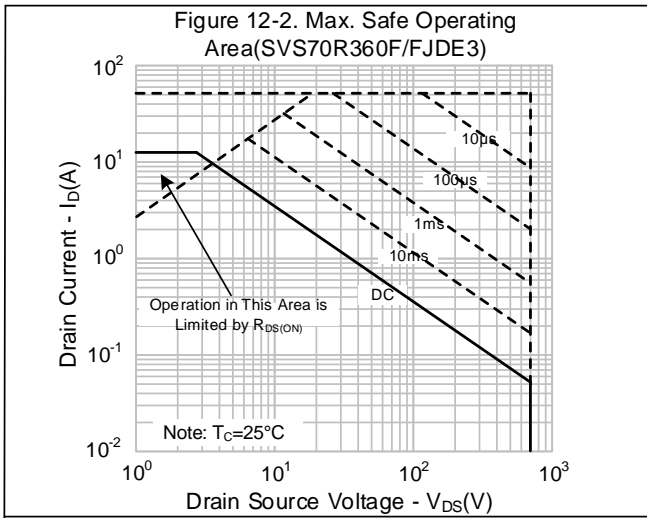

TYPICAL TEST CIRCUIT

Gate Charge Test Circuit & Waveform

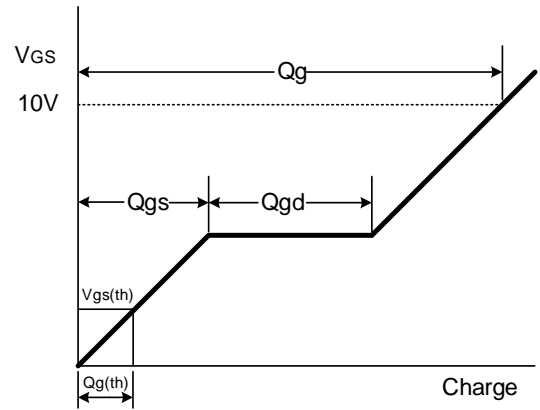
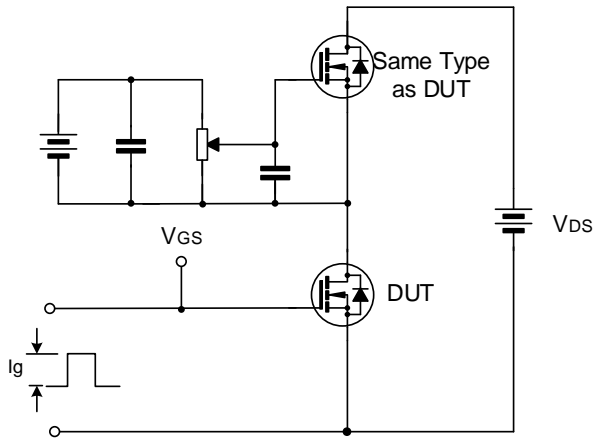

Resistive Switching Test Circuit & Waveform

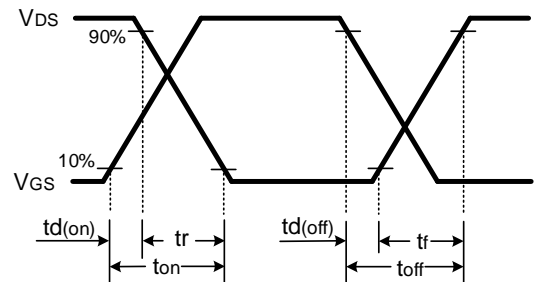
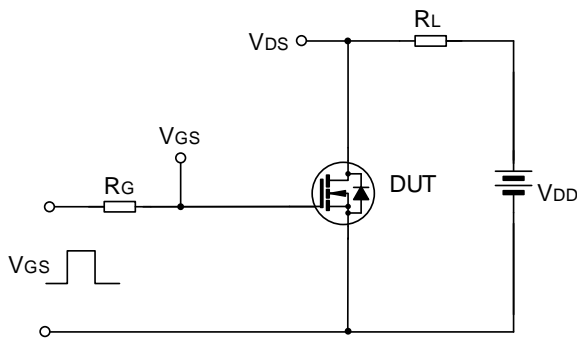

Unclamped Inductive Switching Test Circuit & Waveform

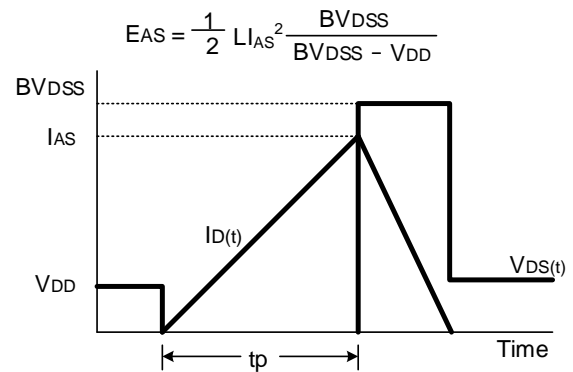
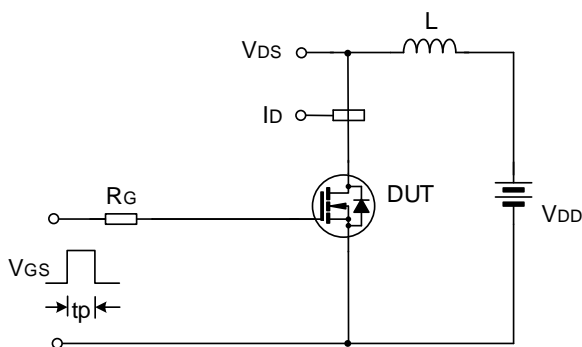

PACKAGE OUTLINE

TO-263-2L

UNIT: mm

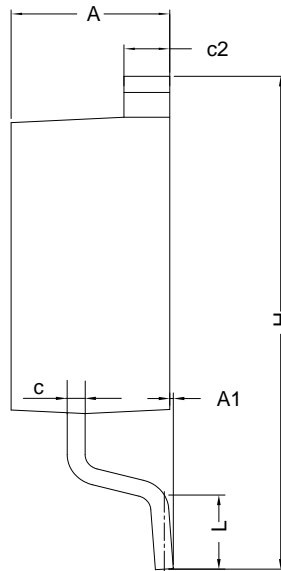
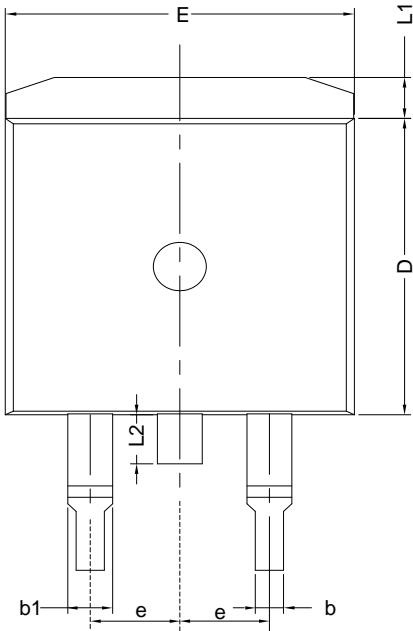

SYMBOL	MILLIMETER		
	MIN	NOM	MAX
A	4.30	4.57	4.72
A1	0	0.10	0.25
b	0.71	0.81	0.91
c	0.30	—	0.60
c2	1.17	1.27	1.37
D	8.50	—	9.35
E	9.80	—	10.45
e	2.54BSC		
H	14.70	—	15.75
L	2.00	2.30	2.74
L1	1.12	1.27	1.42
L2	—	—	1.75

TO-220F-3L

UNIT: mm

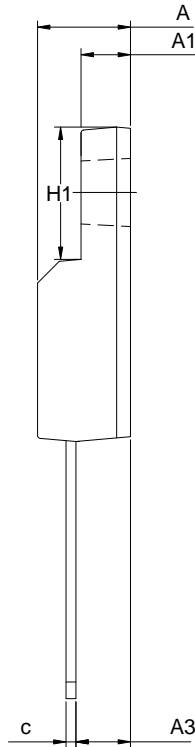
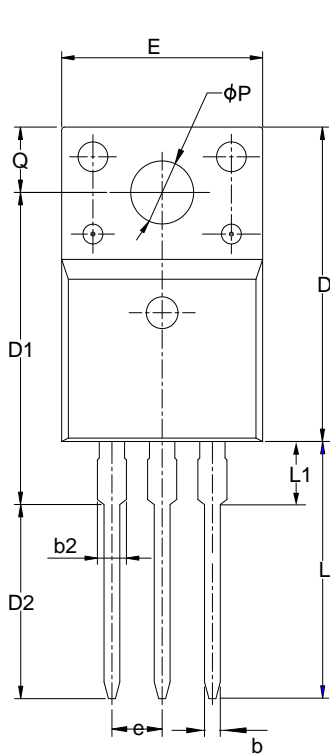

SYMBOL	MILLIMETER		
	MIN	NOM	MAX
A	4.42	4.70	5.02
A1	2.30	2.54	2.80
A3	2.50	2.76	3.10
b	0.70	0.80	0.90
b2	—	—	1.47
c	0.35	0.50	0.65
D	15.25	15.87	16.25
D1	15.30	15.75	16.30
D2	9.30	9.80	10.30
E	9.73	10.16	10.36
e	2.54BSC		
H1	6.40	6.68	7.00
L	12.48	12.98	13.48
L1	—	—	3.50
φP	3.00	3.18	3.40
Q	3.05	3.30	3.55



PACKAGE OUTLINE(CONTINUED)

TO-220FJD-3L

UNIT: mm

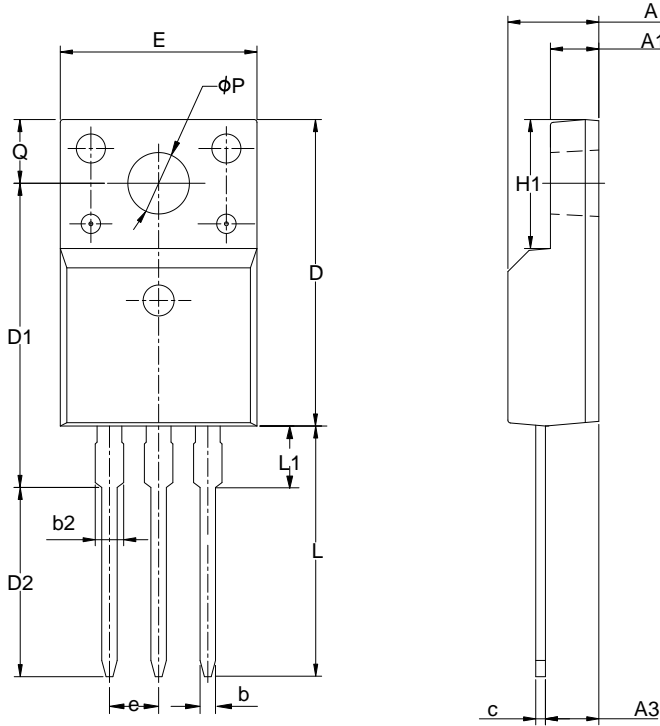

SYMBOL	MILLIMETER		
	MIN	NOM	MAX
A	4.42	4.70	5.02
A1	2.30	2.54	2.80
A3	2.50	2.76	3.10
b	0.55	0.70	0.85
b2	—	—	1.29
c	0.35	0.50	0.65
D	15.25	15.87	16.25
D1	13.97	14.47	14.97
D2	10.58	11.08	11.58
E	9.73	10.16	10.36
e	2.54BSC		
H1	6.40	6.68	7.00
L	12.48	12.98	13.48
L1	—	—	2.00
phi P	3.00	3.18	3.40
Q	3.05	3.30	3.55

TO-252-2L

UNIT: mm

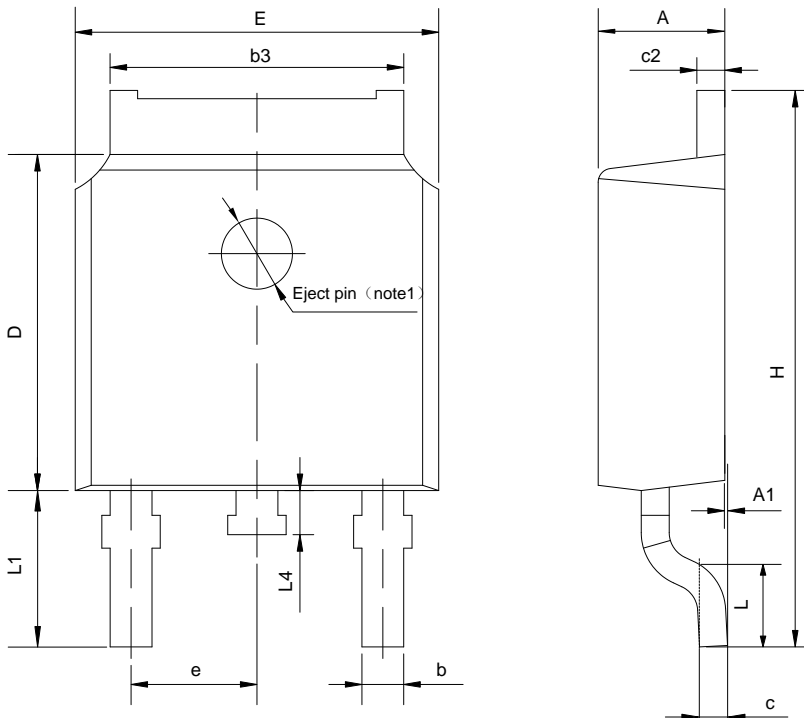

SYMBOL	MILLIMETER		
	MIN	NOM	MAX
A	2.10	2.30	2.50
A1	0	—	0.127
b	0.66	0.76	0.89
b3	5.10	5.33	5.46
c	0.45	—	0.65
c2	0.45	—	0.65
D	5.80	6.10	6.40
E	6.30	6.60	6.90
e	2.30TYP		
H	9.60	10.10	10.60
L	1.40	1.50	1.70
L1	2.90REF		
L4	0.60	0.80	1.00

NOTE1 : There are two conditions for this position:has an eject pin or has no eject pin.



Important notice :

1. The instructions are subject to change without notice!
2. Customers should obtain the latest relevant information before placing orders and should verify that such information is complete and current. Please read the instructions carefully before using our products, including the circuit operation precautions.
3. Our products are consumer electronic products or the other civil electronic products.
4. When using our products, please do not exceed the maximum rating of the products, otherwise the reliability of the whole machine will be affected. There is a certain possibility of failure or malfunction of any semiconductor product under specific conditions. The buyer is responsible for complying with safety standards and taking safety measures when using our products for system design, sample and whole machine manufacturing, so as to avoid potential failure risk that may cause personal injury or property loss.
5. It is strongly recommended to identify the trademark when buying our products. Please contact us if there is any question.
6. When exporting, using and reselling our products, buyer must comply with the international export control laws and regulations of China, the United Nations, the United States, Japan, the United Kingdom, the European Union and other countries & regions.
7. Product promotion is endless, our company will wholeheartedly provide customers with better products!
8. Website: <http://www.silan.com.cn>

Part No.: SVS70R360S(F)(FJD)(D)E3

Document Type: Datasheet

Copyright: HANGZHOU SILAN MICROELECTRONICS CO.,LTD

Website: <http://www.silan.com.cn>

Rev.: 1.2

Revision History:

1. Add TO-252-2L)Add Fig12-2 and 13-3
-

Rev.: 1.1

Revision History:

1. Add SVS70R360FE3(TO-220F-3L) and SVS70R360FJDE3(TO-220FJD-3L)
-

Rev.: 1.0

Revision History:

1. First release
-
-